



Project B-713

January 17, 2003

Extended Service Status – Bulkhead Flats

Attached are the shop instructions for the modification to meet AAR Extended Service requirements in accordance with Rule 88 for the following car series:

BN 614801-614827	BNSF 585396-585400	(Original Series MDW 1000-1086)
BN 626001-626034	BNSF 552303-552331	
BN 626035-626054	BNSF 552332-552348	

CONTENTS

Procedure	Page 2
Side Sill Reinforcement – BN DWG 107170.....	Page 3
AAR Approval Letter	Page 4
AAR Submission Packet	See Historical File

MATERIAL REQUIRED

Per Car

1. 12 D-3 Inner Springs.
2. WABCOPAC to WABCOPAC-II Brake System Conversion.

PROCEDURE:

1. Work cars in accordance with BNSF General Shop Specifications and also the Supplemental Specification for Bulkhead Flat cars.
2. Ensure side sill reinforcement has been applied in accordance with BN DWG 107170.
3. Add three (3) D-3 Inners to each spring nest to a 7 D-3 outer & 7 D-3 inner configuration.
4. Update spring configuration stencil on the ends of the car to reflect 7 D-3 Outer and 7 D-3 Inner.
5. Apply WABCOPAC-II Brake System in accordance with WABTEC instructions.
6. Modify A-End $\frac{3}{4}$ -inch cylinder pipe to obtain proper equalization pressure (63.5-65.5 psi).
7. Stencil the letters "EXS" in the consolidated stencil to the right of the built date in 1-inch block letters to indicate that the car has Extended Service Status.
8. Update Field 65 in UMLER to reflect Extended Service (Enter code "C" for approved for extended service).
9. Enter Job Number B-713 in Shop Release Program.

Questions or comments should be directed to the BNSF Mechanical Engineering Department at 817-352-1469

BN SERIES	WHERE USED	LINE NO.
626001 - 626034	89'-1" BULKHEAD POLE CARS	1
626035-626054		2

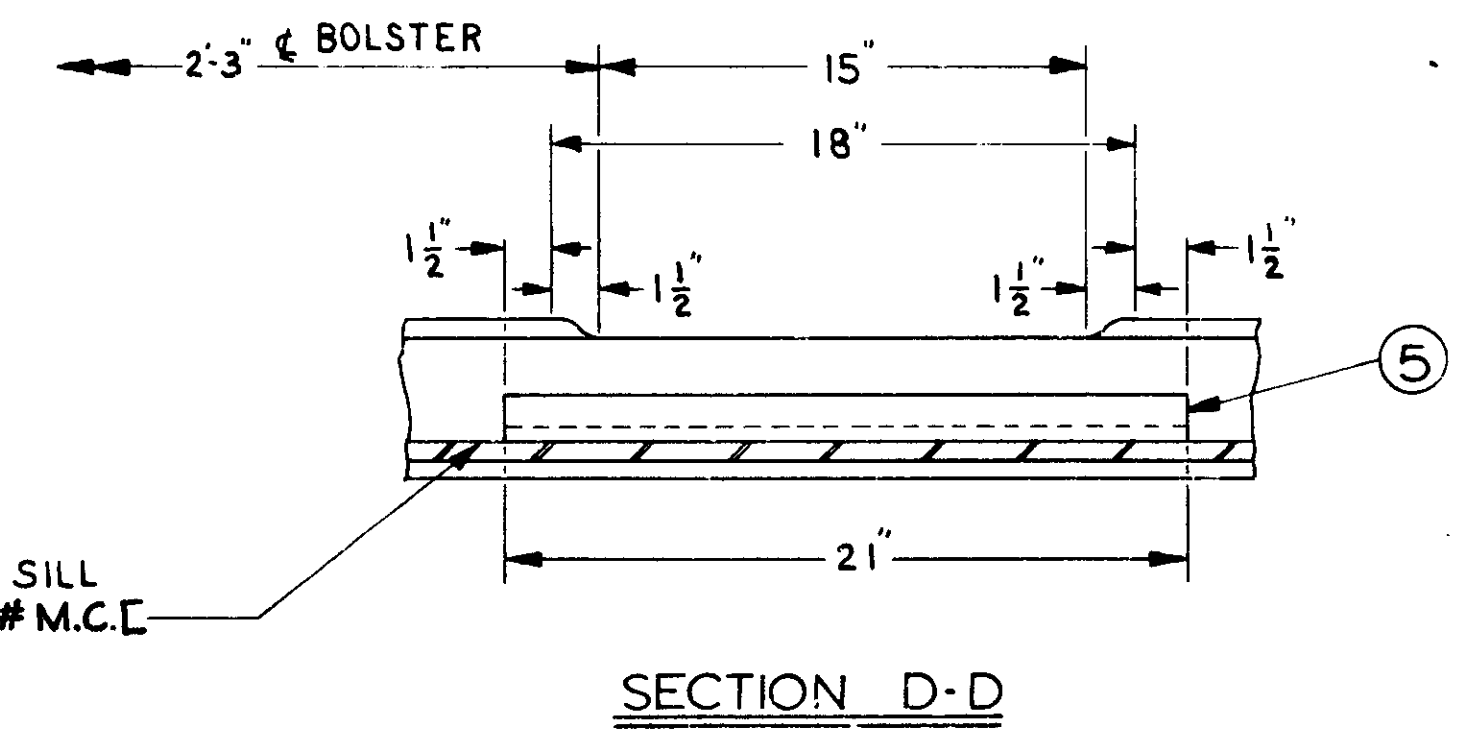
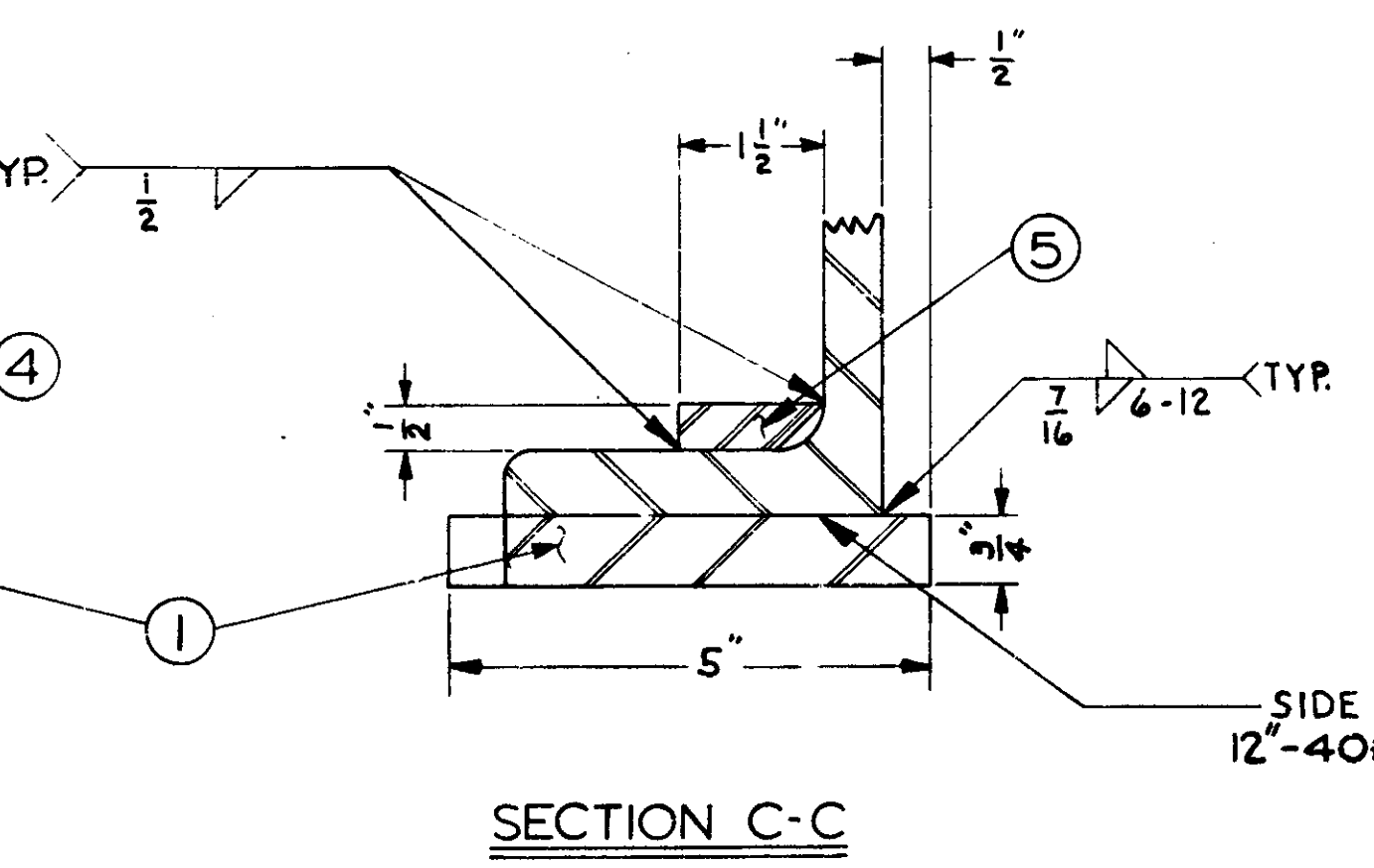
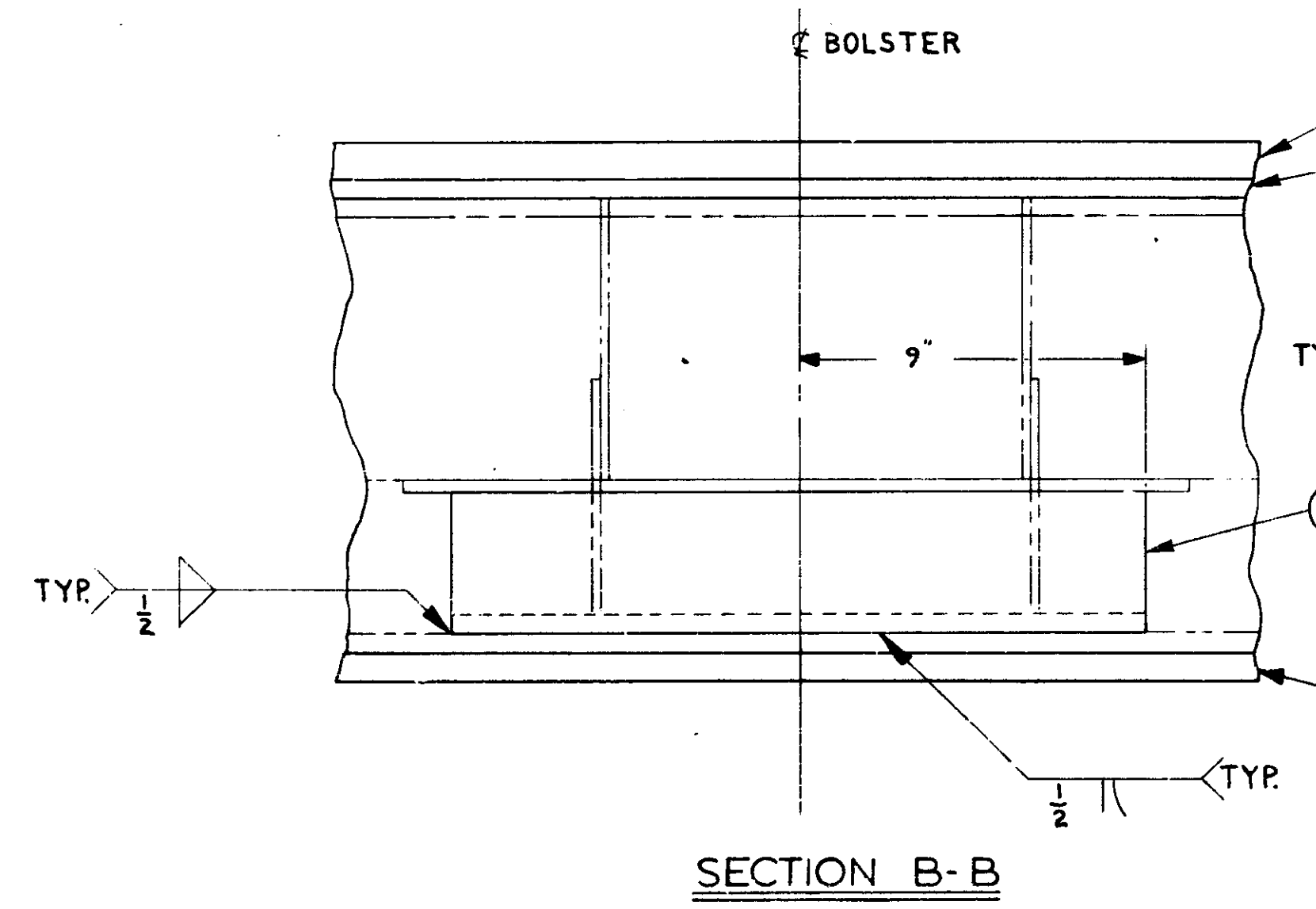
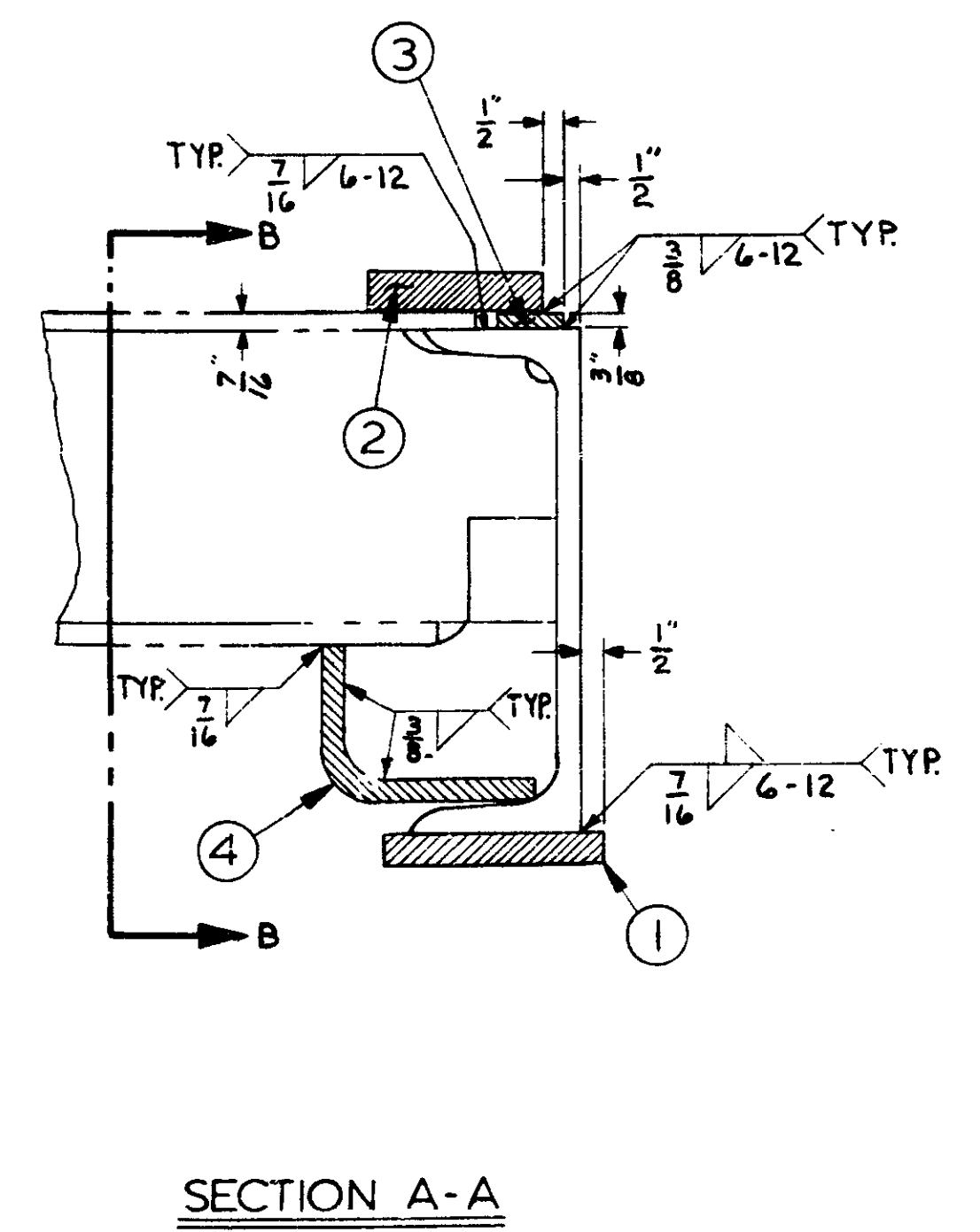
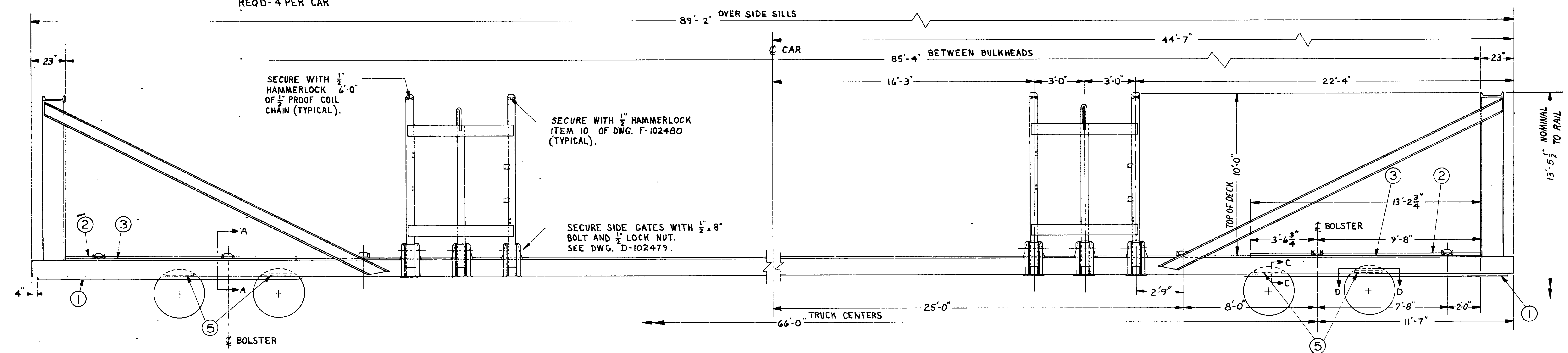
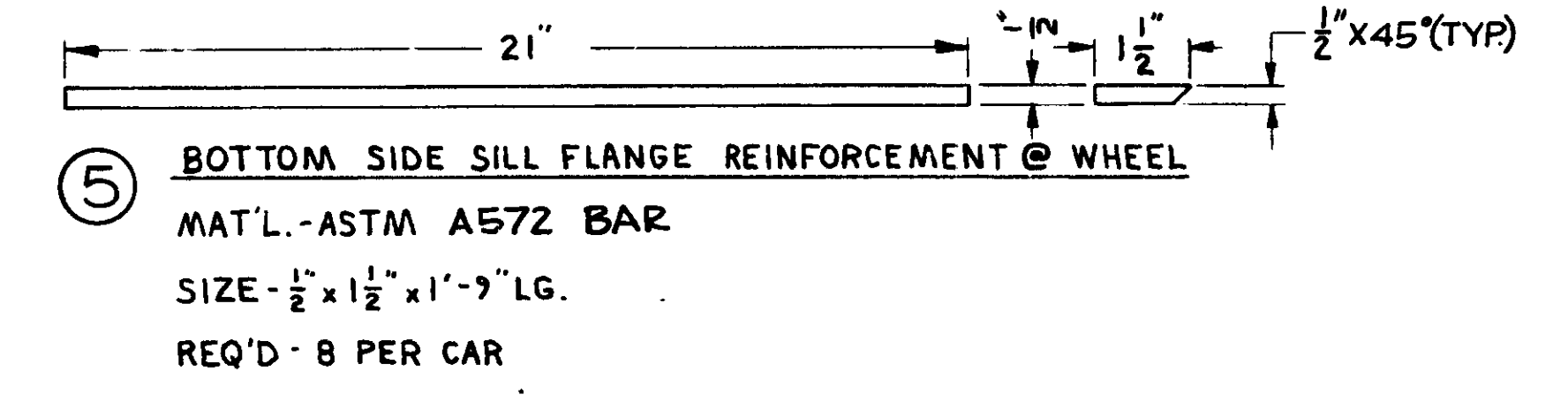
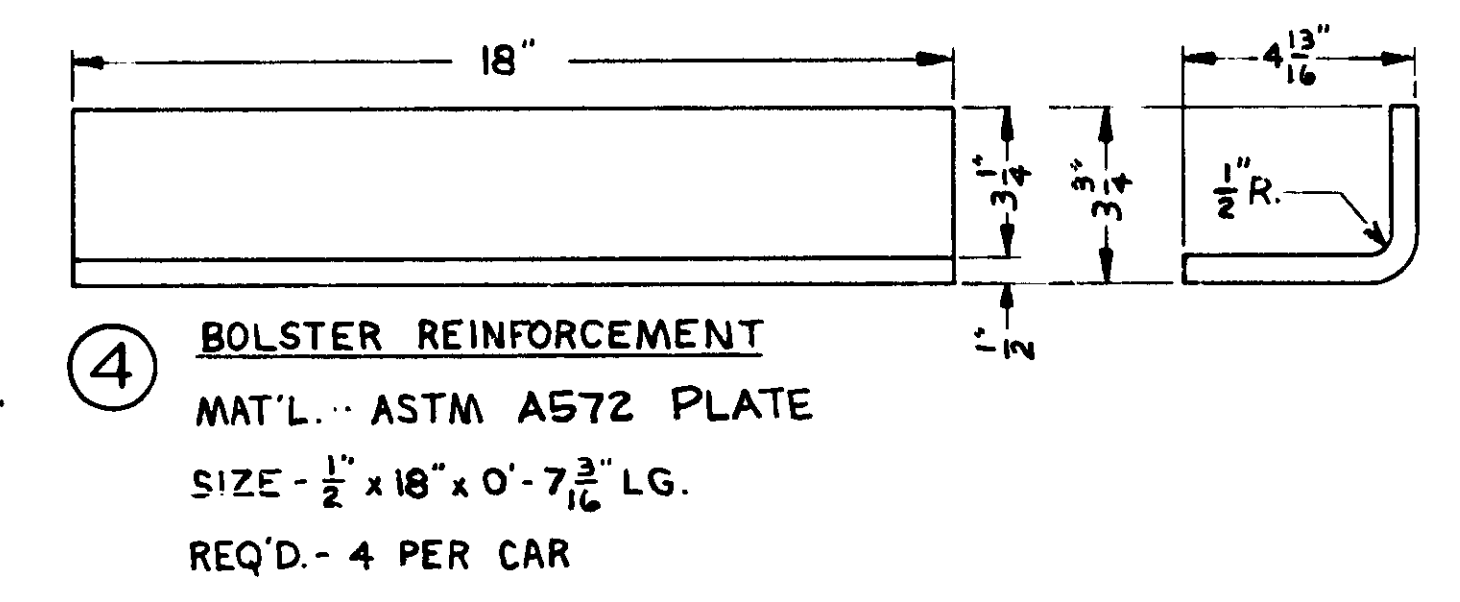
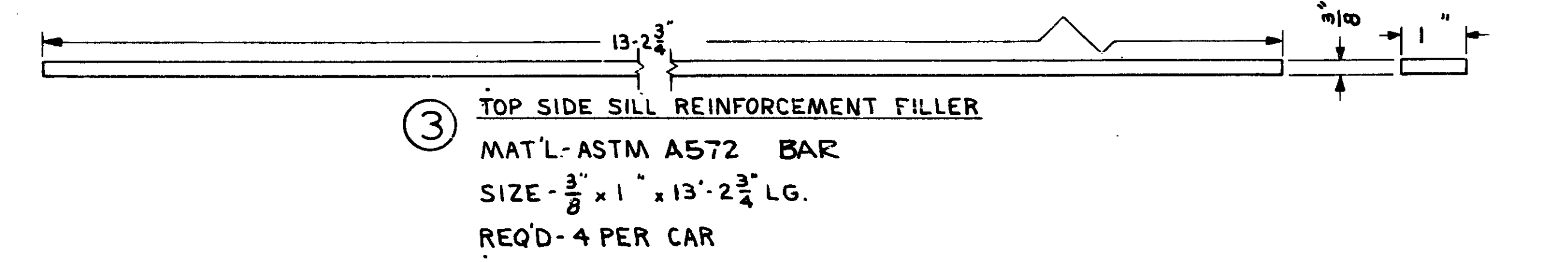
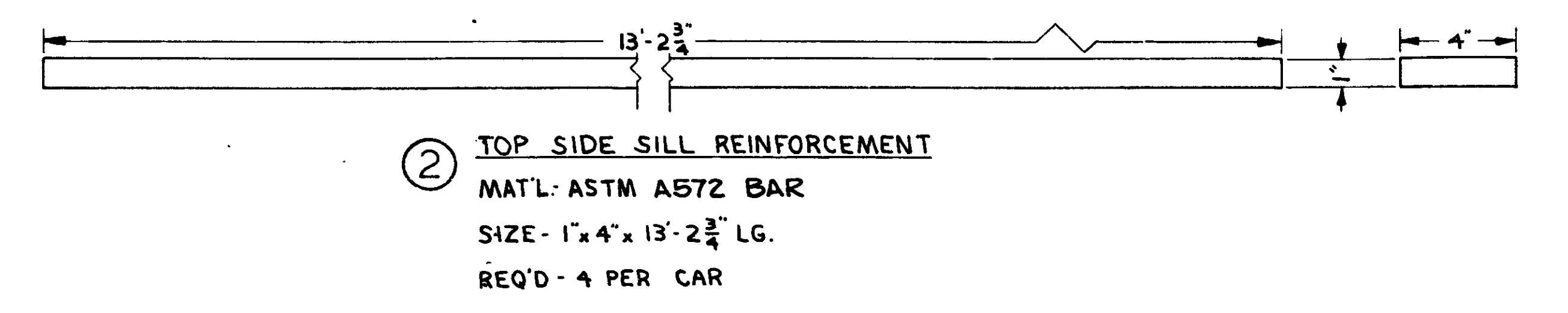
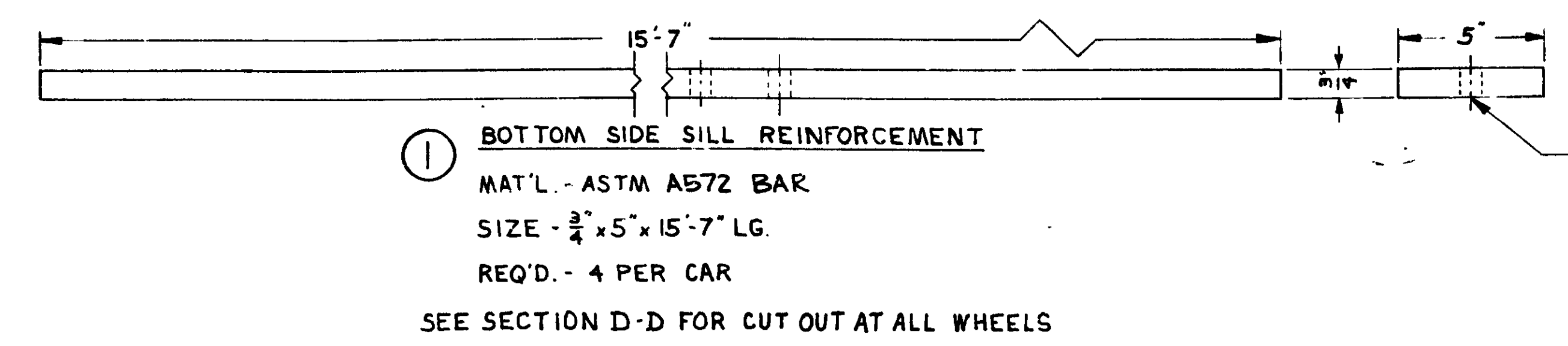

CUT OUTS TO BE MADE BEFORE APPLYING TO CAR.

REFERENCE DRAWINGS	DRAWING NO.
SAFETY APPLIANCE APPLICATION	D-107153
BULKHEAD ASSEMBLY	D-107154
BULKHEAD DETAILS	D-107155
BULKHEAD DETAILS	D-107156
END LADDER ASSEMBLY	D-107157
TENSION TIE APPLICATION	D-107158
GRAB & TREAD DETAILS	D-107159
CAR NUMBER PLATE & APPLICATION	C-107166
BRAKE STEP SUPPORTS	D-107167
HAND BRAKE ARRANGEMENT	D-107168
SILL STEP DETAIL & APPLICATION	D-107169
STAKE POCKET ASSEMBLY	D-102479
SIDE GATE ASSEMBLY	F-102585
STENCIL ARRANGEMENT	H-105119
DECK RISERS	C-105188

APVD	CKD.	DATE	12-30-74	DO NOT SCALE DWG.
BURLINGTON NORTHERN MECHANICAL DIV. ST. PAUL, MINN.		DATE	12-30-74	DO NOT SCALE DWG.
GENERAL ARRANGEMENT		DATE	12-30-74	DO NOT SCALE DWG.
BY	REV.	DATE	1/1	DRAWING NO. 107170

P. T. Ameen
Assistant Vice President
Technical Services

Thomas J. Stahura
Executive Director
Rules and Standards

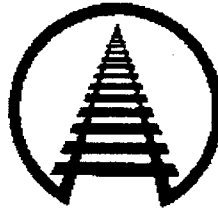

**ASSOCIATION OF AMERICAN
RAILROADS**

C. R. Ice
Chairman, Technical Services
Working Committee

B. J. Pague
Secretary

October 21, 2002

Subject: Gunderson/TTS Request for Extended Service Status of Three Series of BNSF Bulkhead Flat Cars BN 614801- 614827, 626001- 626034, 626035- 626054 (50 Cars)

CC-201.101.21

Mr. Scott Landrum
Transportation Technology Services
1540 Edinburgh Lane
Keller, TX 76248

Dear Mr. Landrum:

I am pleased to advise that our review process is complete on the subject group of cars, which was submitted in your letter of August 14, 2002. These cars are therefore approved for Extended Service Status under Office Manual Rule 88.C.1.f. (1) (c with the understanding that any repairs, modifications or upgrades required by the Minimum Mechanical Standards Chart of Paragraph C.3 of Rule 88 will be performed on each car.

Please see that the necessary information changes are provided to UMLER as these cars are reconditioned and released. If you have any questions please do not hesitate to contact Mr. Charles Powell of our Transportation Technology Center, Inc. subsidiary at (719) 585-1883.

Sincerely,

A handwritten signature in cursive script that reads "Thomas J. Stahura". The signature is written in black ink and is positioned above the printed name.

Thomas J. Stahura

TJS/csp
cc: David Meeks
Keith Hawthorne
J. Moran
Equipment Engineering Committee